

GUARDING TO KEEP TEAMS SAFE



EXPLORE OUR GUARDING PACKAGES

When it comes to guarding your most important asset - your people - we can help. Explore the various options we have for safety guarding on our equipment, designed to meet your specific requirements.

Full Perimeter Guarding

Full Perimeter Guarding features full access doors to your machine. Doors made from lexan material with stainless steel frame. Stainless steel options are available.

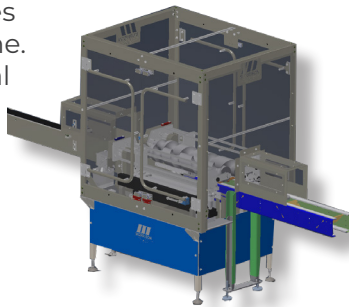

Top-Cover Guarding

Top-Cover Guarding features a top lift off cover, or it can be hinged. It mounts to your existing conveyor to provide protection and reduce access to the system. Doors made from lexan material with stainless steel frame.

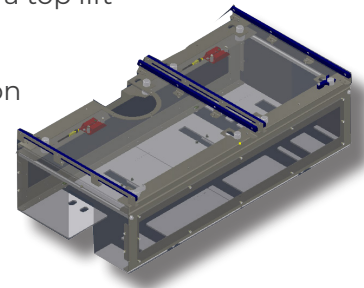

Gull-Wing Guarding

Gull-Wing Guarding features two hinged doors on each side of your machine. The doors have gas struts to keep the door from falling down and to make the doors feel virtually weightless upon opening. A base frame is included to support the guarding structure. This guarding is lock out / tag out capable.

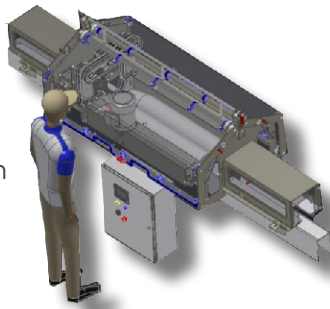

Stainless Steel Top-Cover Guarding

Stainless Steel Top Cover Guarding features honeycomb stainless steel design for high-washdown environments and mounts to your existing conveyor. The honeycomb design removes lexan from the build while still allowing operators to see into the machine. Design can include top lift off cover or be hinged.

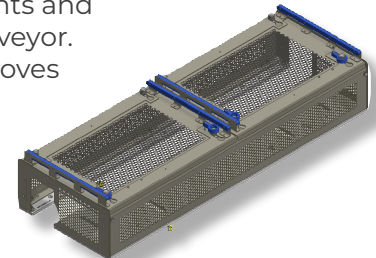

Full Perimeter Guarding

Gull-Wing Guarding

Top Cover Guarding

Stainless Steel Top Cover Guarding

