

MORRISON PARTS CARTS

EASILY STORE YOUR CONTAINER HANDLING SETS

We develop our customizable rolling storage carts to smoothly organize all your container handling sets into one portable storage unit. We give you the coordination, space, and efficiency you need to optimize your production line. These products are developed and produced to provide flexible and responsive solutions to the packaging industry.

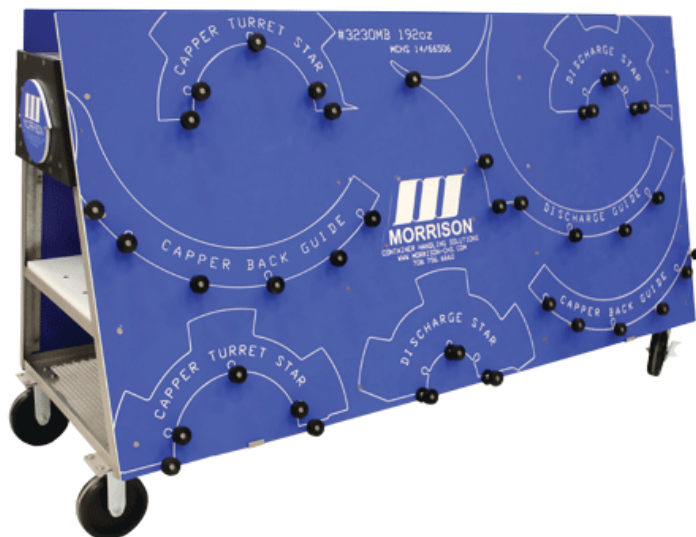

BUILT TO FIT YOUR UNIQUE NEEDS

PARTS CARTS **DESIGNS**

STANDARD A-STYLE PARTS CART

The Standard A-Style Parts Cart is the most commonly used parts cart. The cart has a footprint of 96" x 36" and is roughly 56" tall from the ground up.

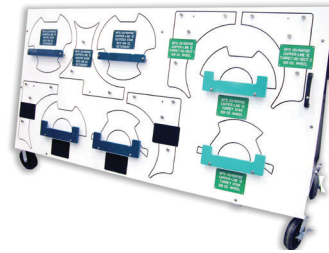

A-STYLE PARTS CART WITH SHELF AND 3 TIMING SCREW TUBES

This cart is typically used when the number of timing screws required to fit on the cart exceeds the capacity of the Standard A-Style Parts Cart. The non-standard A-Style Carts have the same measurements as the standard A-Style Cart.

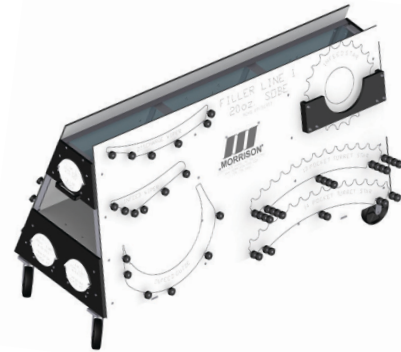

H-STYLE PARTS CART

This parts cart is usually requested by customers that require a smaller parts cart footprint. The H-Style cart has limited room for mounting timing screws (typically 2 on the front of the cart). The footprint is roughly 48" x 32" and 68" from the ground up.

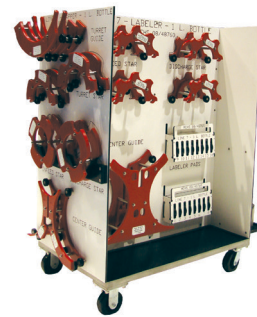

CUSTOM DESIGNED PARTS CART

For the most custom applications, Morrison will design a parts cart unique to your needs. Our designs are innovative and adaptable to any production line and our engineers will work with you to create a solution that fulfills all your needs.

